

Carrello coibentato applicabile sia in zona vendita che nei reparti di lavorazione alimentare/stoccaggio
Insulated cart for food retail area, food process and cold storage applications



RBC200 – cm.82x71x71h
185 litri //liters

RBC300 - cm.84x74x99h
300 litri //liters

RBC500 - cm.131x98x92h
500 litri//liters

in materiale plastico coibentato per aumentare l'isolamento termico; con ruote in nylon e maniglie per facilitare la movimentazione; provvisto di scarico acqua e rubinetto.

Made of double insulated plastic material, with nylon wheels and ergonomyc handles for easy maneuverability; water drain with faucet.



Carrello coibentato applicabile sia in zona vendita che nei reparti di lavorazione alimentare/stoccaggio
Insulated cart for food retail area, food process and cold storage applications

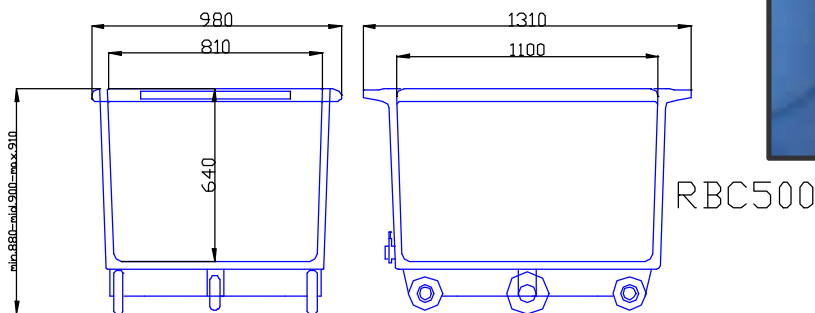
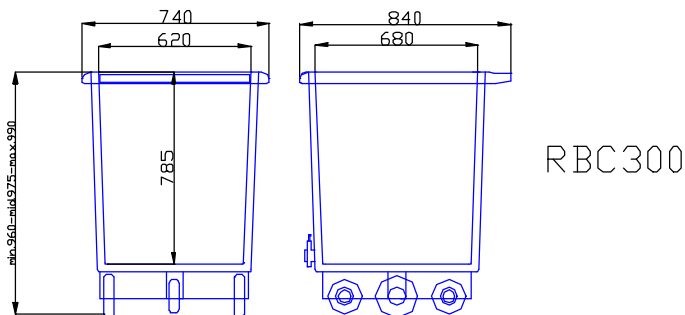
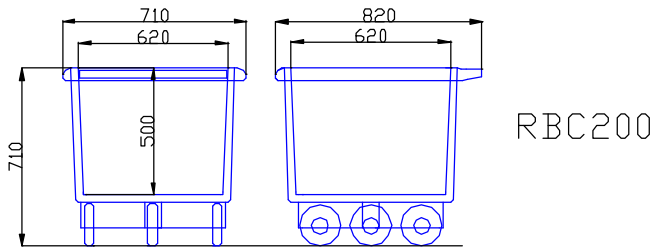

Valvola di scarico prevista nei modelli RBC300 e RBC500



Faucet for water drain standard on RBC300 and 500



Modello <i>model</i>	Dimensioni LxPxH <i>Overall size WxDxH (cm)</i>	Peso lordo <i>Gross Weight</i>
RBC200	71x82x71	22 Kg
RBC300	74x84x99	36 Kg
RBC500	98x131x92	42 Kg